

RADIOCONTACT
LIMITED



**WIRELESS TRANSMISSION
PRODUCTS
INSTALLATION GUIDE**

T-LINK 458MHz

SECTION 1

1. General Guidelines For The Installation Of Radiocontact RF Equipment.

1.1. General

Prior to any purchase of RF equipment a site survey should take place to determine if the equipment selected is suitable to the job in hand. During this visit particular attention should be paid to the mounting locations of the transmitter and receiver equipment. An estimate of transmission range should be made taking into consideration the height of the Rx/Tx equipment and its location to ensure direct line of site between Rx and Tx antennas.

It is important that before purchasing RF modems or video transmission equipment that the installation, application and specification documentation of the third party equipment to be integrated be carefully studied to ensure compatibility in terms of data rate, data protocol and video levels. Radiocontact Ltd cannot be held responsible for systems failing to operate correctly due to compatibility problems.

Before taking equipment to the customers site for installation ensure sufficient lab testing has been carried out to be familiar with the equipment and to confirm correct operation of all equipment to be installed, including third party equipment..

1.2. Field Trials

Before mounting the RF equipment permanently a Field Trial should be carried out to ensure the equipment will function satisfactorily at the site. This is particularly important in areas where there are steel structures, buildings, moving vehicles such as cars, cranes, trains etc. Checks should be made to ensure the required transmission range can be achieved and that there is no degradation of video picture quality or corruption of transmitted data due to other localised transmission equipment radiating on or near your selected frequency. Should interference be detected then it will be necessary to change transmission channel to avoid the interference. However should this not be possible then alternatives should be considered such as the use of directional antennas (on receiving equipment only).

1.3. Antenna Mounting

It is essential that all antennas should be mounted as high as possible from the ground. There should be no obstructions such as trees, buildings or cranes that could interfere with the direct line of sight.

Equipment fitted with built-in stub antennas should be mounted with the antenna vertical. Sufficient space should be left between the antenna and the mounting pole or wall not to distort the RF signal. Normally a clearance space of 20 cm is required. This is to ensure maximum gain from the antenna. Buildings usually absorb some of the radiated energy while metal poles and towers can generate reflections producing "ghosting" on video systems and loss of data on telemetry systems. See Figure 1 for optimum mounting positions.

The maximum range of Radiocontact systems can be increased using high gain directional antennas such as the CCT2440/ANT10, 458/ANT and CP17. However it is important to ensure these are mounted as high as possible and aligned towards the transmitter antenna. These antennas can only be used on the Receivers. **It is illegal to fit these high gain antennas to Radiocontact transmitters as this will compromise the requirements of the License Exempt regulations to which the equipment has been Type Approved and could cause serious interference to other users.**

In cases where multiple antennas are required to be mounted on the same mast, then a separation distance of approximately 1m should be maintained between antennas. This is to avoid interference problems between the various receiver or transmitter local oscillator and sub-harmonic frequencies.

It should be noted that accurate antenna alignment cannot be carried out until the equipment is permanently installed. It may be necessary to move either the Tx or Rx antenna to optimise video picture or data quality. Small movements of up to ¼ wavelength can mean the difference between poor signal and good signal. A ¼ wavelength at 400 – 500MHz is 16cm and 2.4GHz is 3cm.

Figure. 1: Antenna Mounting

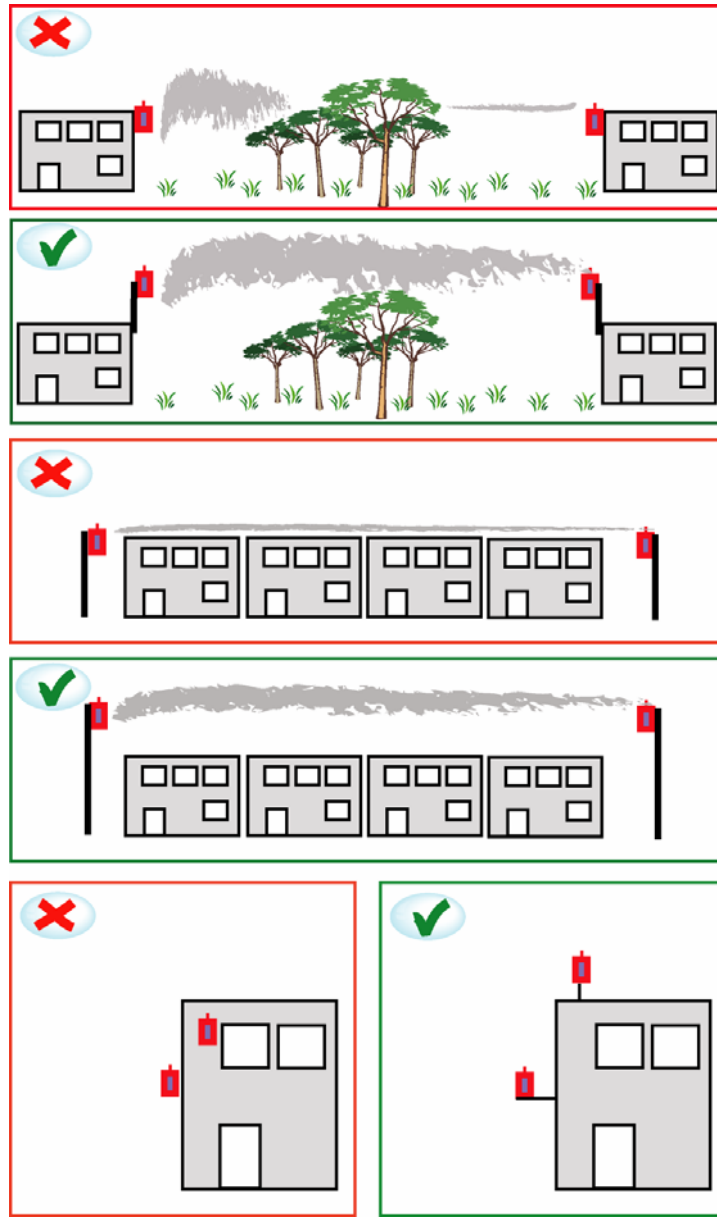

1.4.

Power Supplies

Only use analogue Power supplies

All Power Supplies used with Radiocontact RF modems and Video Transmission equipment **MUST** be analogue and **NOT** Switch Mode. These power supplies generate and radiate a high level of switching noise at a frequency of around 150 – 200KHz. This can cause interference lines on video transmission equipment and corrupt data bits on RF modems. It should also be noted that Radiocontact RF equipment operates from 12V DC . A normal tolerance on this voltage would be $\pm 0.25V$.

Do not use Power supplies designed for charging batteries

It is **NOT** permissible to operate this equipment from 12V rechargeable batteries as the output voltage from batteries of this type can be as high as 13.6V and can damage equipment. Should it be necessary to operate equipment from this type of battery then a suitable 12V DC regulator should be employed.

Do not share Power supplies with other equipment

Should it be necessary to power up several RF modems or video transmitters at the same location then separate analogue power supplies must be used. This is to prevent interference and crosstalk between the different systems.

Confirm 12V at the equipment end

All power supplies should be mounted as close as possible to the equipment. In situations where this may not be possible care should be taken to ensure that suitable low resistance cable is used for power connections. This is to minimise voltage drop along the power cable. When installation is complete it is necessary to measure the 12V DC supply **AT THE EQUIPMENT END** not the power supply to ensure it is within the $\pm 0.25V$ recommended limit.

1.5. Safety

The installation of RF and CCTV equipment involves the equipment being installed at considerable heights outside buildings or on masts. It is essential that **ALL** Health and Safety Regulations are adhered to regarding the wearing of safety equipment.

SECTION 2

T-LINK 458/433MHz Telemetry Equipment

The T-Link telemetry system is RF equipment therefore the installation guidelines detailed in Section 1 apply, and should be thoroughly read and understood.

This equipment is capable of transmitting RS232, RS485, 20mA Current Loop and TTL protocols at data rates up to 4800baud. The required data protocol is selected via the 4-pole DIP switch mounted on the internal PCB. Settings are as tabulated below. To access the Mode Select and Frequency Select switches remove the 4 screws on the rear panel containing the 9-way 'D' I/O connector. Remove the antenna connector retaining nut and withdraw the PCB assembly.

Mode	Tx	Rx
RS485	1	4
RS232	2	3
TTL	3	2
20mA Current Loop	4	1

Note: *Ensure that only one DIP switch is set to ON.
Ensure your equipment supplies at least 10mA of Current Loop signal*

Frequency selection is via 4 pin DIP switch mounted on the underside of the RF Transmitter Module which is also mounted on the PCB. Channels may be selected by setting the DIP switch as shown below.

T-Link Transmitter

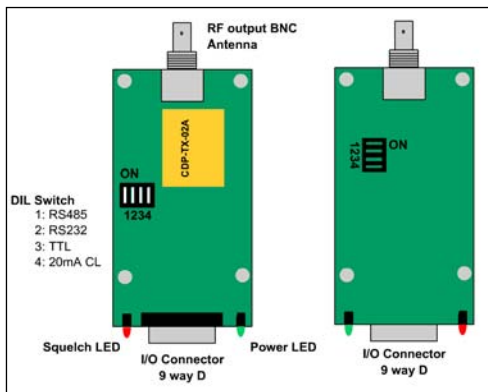

T-Link Receiver

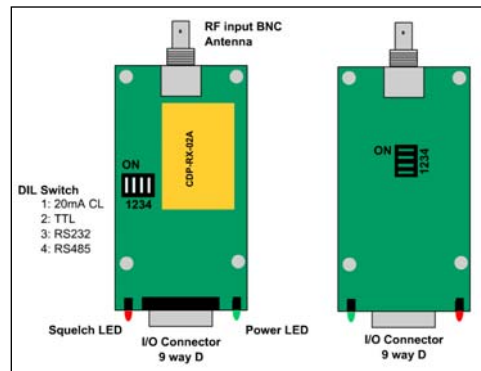

Channel No.	Fo MHz	Switch Position			
		1	2	3	4
Ch. 1	458.525	On	On	On	On
Ch. 2	458.550	Off	On	On	On
Ch. 3	458.575	On	Off	On	On
Ch. 4	458.600	Off	Off	On	On
Ch. 5	458.625	On	On	Off	On
Ch. 6	458.650	Off	On	Off	On
Ch. 7	458.675	Off	Off	Off	On
Ch. 8	458.700	Off	Off	Off	On
Ch. 9	458.725	On	On	On	Off
Ch. 10	458.750	Off	On	On	Off
Ch. 11	458.775	On	Off	On	Off
Ch. 12	458.825	Off	Off	On	Off
Ch. 13	458.8375	On	On	Off	Off
Ch. 14	458.900	Off	On	Off	Off
Ch. 15	458.825	On	Off	Off	Off
Ch. 16	458.900	Off	Off	Off	Off

Note:- Before installation ensure matching Rx and Tx modules have the **same channel selected**.

Input/Output Connections

Input / Output connections to the equipment are via a standard 9 way D type connector (supplied).

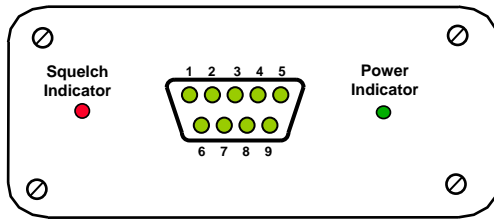

Power ON Indicator

This green LED will illuminate when 12V DC power is applied between pins 5 and 6 of the 9-way 'D' connector. If the LED is not lit check the following:-

- a) The power supply is cabled to the T-Link unit and the 230V AC mains supply
- b) The power supply is connected to the 9-way 'D' connector with the correct polarity. (Note that these telemetry units are reverse polarity protected to prevent damage)
- c) The power supply is switched ON.

Squelch Indicator

The squelch indicator on the transmitter will illuminate whenever data is present at the correct pins of the 9-way 'D' connector, depending on the data protocol to be used. If no data is present this LED will not illuminate and the internal transmitter module will not be powered

The squelch indicator on the receiver will illuminate when it receives an RF signal from the transmitter unit, indicating that the transmitter is operating and that both Rx and Tx are on the same frequency.

9-way 'D' pin connections are the same for both Rx and Tx and are as follows:-

Pin	Function
1	Not Used
2	20mA Current Loop I+
3	TTL
4	RS232
5	GND
6	+12V DC 300mA
7	20mA Current Loop I-
8	RS485 B
9	RS485 A

GENERAL TROUBLESHOOTING GUIDELINES

The following section describes some of the most common problems encountered during installations of both video and telemetry equipment, and possible solutions. Frequency and data selection links should be installed after this installation manual has been thoroughly read and understood and before the equipment is installed in its final location. The first things to check are the following:

No reception of any kind

1. Check power supply is ON, and power is being delivered to the equipment, i.e. +12V at the connector.
2. Ensure correct polarity is used at the power connector, i.e. centre pin +ve.
3. Ensure the power supply is of the correct rating for the equipment, i.e. 12V Reg. 500mA
4. Check that the power supply is not shared with any other devices.
5. Make sure the correct channel on both Rx and Tx has been selected.
6. Make sure the units are not installed near metallic surfaces.
7. Check antennas have been correctly fitted and there is direct line of sight.

Poor reception/Poor Quality Picture or Data

Causes of this problem can be varied but generally fall into 3 categories:-

Weak received signal – poor system sensitivity
Same channel interference
Adjacent channel interference

Weak received signal – poor system sensitivity

If the video picture quality or data quality is poor check the following:

1. Transmission range is within the capabilities of the equipment used.
2. Antennas should be the correct frequency for the equipment and screwed tightly to the transmitter/receiver.
3. Rx/Tx equipment should be mounted as high as possible with direct line of sight.
4. Ensure equipment is mounted off the support structure as described in Section 1 as antennas mounted close to metal structures can cause signal reflections and multi-path effects which reduce the strength of the signal appearing at the receiver.
5. Due to the nature of RF signal transmission, increases in sensitivity can be achieved by moving the position of equipment by a few centimetres. This may increase the signal strength enough to resolve the problem.
6. Switch off the transmitter and observe output of the receiver. For Video systems “snow” should be seen on the monitor. If another picture or distorted image is present then the problem is due to external interference and a different channel should be selected. For Telemetry systems if the Red squelch LED is on or flickers then again the problem is due to external interference and a different channel should be selected. (see same channel interference)

Reduced sensitivity can also be caused by strong signals in the same frequency band but not on the operating frequency. This has the effect of swamping the front end of the receiver causing it to partially or fully shut down due to the operation of its internal Automatic Gain Control (AGC) circuits. This leads to a loss in sensitivity and a reduction in the strength of the signals at the receiver. This type of problem should be identified during the initial site survey. The solution is to change transmission channel on both Rx and Tx modules until the problem disappears. Should it not be possible to find a “good” channel then the source of the interfering signal must be found and agreement reached on either changing frequency or time sharing.

Adjacent Channel interference

Adjacent channel interference is where another transmission system is broadcasting on one of the other channels within the band you are using. Problems of this nature normally only exist if the other transmission source is mounted too close to close to your receiver. The normal solution to this problem is to increase the separation distance between the two equipments concerned or to select another channel.

Summary

The following is a list of the most common video transmission problems and troubleshooting information:-

Black picture on the monitor

Make sure both Tx/Rx are powered and on the same channel.

Check that a video source is connected to the input of the Tx and the output of the Rx is connected to the monitor/matrix/mux.

Check video cables for correct connection and if necessary continuity.

Noise (Snow) on the monitor

Make sure Tx is powered.

Check that the Tx channel matches that of the Rx.
Make sure the correct antennas are used and are connected properly.

Scrolling picture

Make sure the V-Hold of the monitor is not responsible.

If the scrolling picture is also of poor quality or dark the video level might be too low causing loss of sync pulse.

Check termination's at both the Transmitter end (if the signal is coming from a source other than a camera) and Receiving end (check for any double terminations).

Check the level of the video source connected to the Tx.

Radiocontact Transmitters have internal termination so for the correct level of 1V p-p to be transmitted the video source must be 2V p-p.

Move the links up - down - left - right and watch the monitor for improved quality.

B&W instead of colour picture on the monitor

Make sure the chroma control of the monitor is not responsible.

Make sure the camera used is not B&W

If the picture is also of poor quality the video level might be too low.

Check termination's at both the Transmitter end (if the signal is coming from a source other than a camera) and Receiving end (check for any double terminations).

Check the level of the video source connected to the Tx.

Move the links up - down - left - right and watch the monitor for improved quality.

Should the problem persist then equipment should be substituted one unit at a time until the defective item is identified

COPYRIGHT & DISCLAIMER

This document is the property of Radiocontact Ltd and the information contained therein may only be used for the purposes authorised; any reproduction in whole or in part may be an infringement of copyright. Permission for reproduction must be obtained from Radiocontact Ltd.

The information contained is provided as a general outline to installation of RF equipment. Radiocontact Ltd reserves the right to change the following technical information without prior notification.

Radiocontact Ltd. does not accept responsibility for any loss or damage resulting from the information contained in this document.

